



LaCie Rugged RAID Shuttle User Manual



Click here to access an up-to-date online version of this document. You will also find the most recent content as well as expandable illustrations, easier navigation, and search capability.

Contents

1	Introduction	4
	Box content	4
	Minimum system requirements	4
	Storage and RAID management	4
	Views	5
	Specifications	5
	• Enclosure dimensions	5
	• Enclosure weight	5
	• Electrical	6
	• Your device might get warm	6
	• Ingress Protection rating	6
2	Activity and Low Power LEDs	7
	Activity LED behavior	7
	Low power LED behavior	7
	Power-saving mode	8
	• Operating system	8
3	Cables and Connectors	10
	USB-C protocols	10
	Cables	10
4	Getting Connected	12
	Connect the USB cable	12
	Check for power	12
	Set up LaCie Rugged RAID Shuttle	13
	• Start here	13
	• Register your device	14
	• Download Toolkit	14
	• Install Toolkit	15
5	Use Toolkit to Set Up Security, Mirror Folders, and More	16
	Enable security	16
	Set up a mirror folder	16
	Start a backup plan (Windows only)	16
6	Manage RAID	17
	Comprehensive RAID management	17

7	Safely Remove Device From Your Computer	19
	Windows	19
	Mac	19
	• Eject via Finder window	19
	• Eject via Desktop	19
8	Optional Formatting and Partitioning	21
	Choosing a filesystem format	21
	• Compatibility with both Windows and Macs	21
	• Optimized performance for Windows	21
	• Optimized performance for macOS	21
	• Learn more	22
	Formatting instructions	22
9	Stand Accessory	23
	Installing the stand	23
10	Frequently Asked Questions	26
	Hard drive icon	26
	File transfers	27
	File transfer error messages	27
	Using a USB hub for USB devices	28
	Provided USB cables	28
	USB 2.0 ports	28
	RAID levels	29
11	Regulatory Compliance	30
	China RoHS	30
	Taiwan RoHS	31

Introduction

Ultra-high capacity, easy-to-use RAID, and self-encrypting Seagate Secure™ technology come together in LaCie Rugged RAID Shuttle. This fast, bus-powered solution is built fittingly flat for gear bags and shipping envelopes, and incredibly tough for whatever terrain your project calls for.

This user manual provides instructions on how to set up your Rugged RAID Shuttle. For common questions and answers about your hard drive, see [Frequently Asked Questions](#) or visit [LaCie customer support](#).

Box content

- LaCie Rugged® RAID Shuttle
- USB-C (USB 3.1 Gen 2) cable
- USB-C to USB-A cable
- External power supply—Use when the [low power LED](#) blinks
- Quick Install Guide



Important info—Save your packaging. If you experience problems with your hard drive and want to exchange it, the hard drive must be returned in its original packaging.

It's recommended that you save the insert listing the secure code and reset codes for your device. The secure code is required to initially enable security for your device. The reset codes are required if you need to reset the drives to their factory settings. Note: If you no longer have the insert, you can find the codes on stickers located under the protective bumper encasing the hard drive.

Minimum system requirements

- Computer with a USB-C, USB 3.0 or USB 2.0 port.
- macOS® 10.12 or later / latest version of Windows® (Windows 7 / Windows 8 / Windows 8.1 / Windows 10)
- 600MB recommended

Storage and RAID management

LaCie Rugged RAID Shuttle storage is managed by LaCie Toolkit. See the [Toolkit user manual](#) for details.

LaCie RAID Manager is a software utility for modifying the RAID configuration. See the [LaCie RAID Manager for 2-Bay Devices user manual](#) for details.

Views

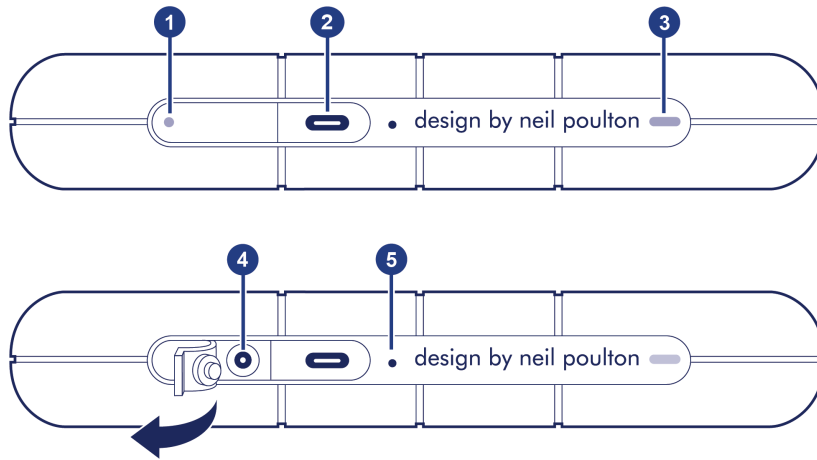

1. **Low power LED**—Blinks if Rugged RAID Shuttle is not receiving enough power from the USB connection to your computer, requiring the use of the included power supply. See [Activity and Low Power LEDs](#).
2. **USB-C (USB 3.1 Gen 1) port**—Connect Rugged RAID Shuttle to a computer. See [Getting Connected](#).
3. **Activity LED**—Indicates Rugged RAID Shuttle’s current activity. See [Activity and Low Power LEDs](#).
4. **Power input**—Connect the power cable to this port if needed. Use only the power cable included with your LaCie Rugged RAID Shuttle. Attaching third-party or other LaCie power cables with incorrect voltage can damage the device. See [Activity and Low Power LEDs](#).
5. **RAID pinhole**—Use the pinhole when confirming a change to your RAID level. See [Manage RAID](#).

Specifications

Enclosure dimensions

Side	Dimensions (mm / in)
Length	28 / 1.102
Width	173.96 / 6.849
Depth	151.96 / 5.983

Enclosure weight

Weight (kg / lbs)
0.96 / 2.116

Electrical

Power supply output

5.4V 2A

- ! Use only the power supply provided with your Rugged RAID Shuttle. Power supplies from third-party devices and other LaCie products can damage your Rugged RAID Shuttle.

Your device might get warm

Your device might feel warm to the touch when copying or moving a large number of files. These conditions are normal. Your device will return to a regular temperature after it's finished copying.

Conditions that lead to a higher ambient temperature may affect performance. For example:

- Leaving the device in direct sunlight for a limited period of time.
- Leaving the device in a hot enclosed space, such as a car on a hot day.

Extended exposure to extreme weather, heat or water will harm the product and/or permanently damage it. All such actions void the warranty.

Ingress Protection rating

The Ingress Protection (IP) rating is a standard for defining the types of protection supported by equipment and devices. The two-digit code for IP lets users know the conditions that the device can withstand. The two digits are independent, with each number representing a different level of protection.

LaCie Rugged RAID Shuttle is rated IP 54 (horizontal mode).

5: Dust protected—Ingress of dust is not entirely prevented, but it must not enter in sufficient quantity to interfere with the satisfactory operation of the equipment.

4: Spraying of water—Water splashing against the enclosure from any direction shall have no harmful effect, utilizing either: a) an oscillating fixture, or b) a spray nozzle with no shield.

Rugged RAID Shuttle has also been tested for the following:

- **Drop resistance**—Dropped from heights up to 1.2 meters / 4 feet (in non-operating mode).
- **Crush resistance**—Driven over by an approximately 1-ton car (1000kg / 2205 lbs).

Activity and Low Power LEDs

Activity LED behavior

The activity LED indicates the status of Rugged RAID Shuttle.

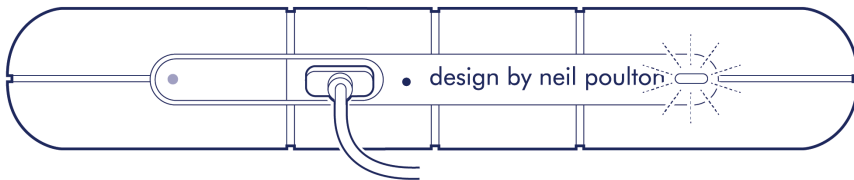

LED	State
On	The device is ready.
Blinking	The device is being accessed.
Fast blinking	A drive is not ready.
Off	Device inactive because it's turned off or in power-saving mode.

Contact [LaCie technical support](#) if:

- **Activity LED remains off while the device is connected to a power supply and to your computer.** Confirm that Rugged RAID Shuttle is not in power-saving mode before contacting LaCie technical support.

Low power LED behavior

Rugged RAID Shuttle is designed to operate using power from the USB connection to your computer. If the connection isn't delivering enough power for Rugged RAID Shuttle to operate, the low power LED behind the protective casing blinks.

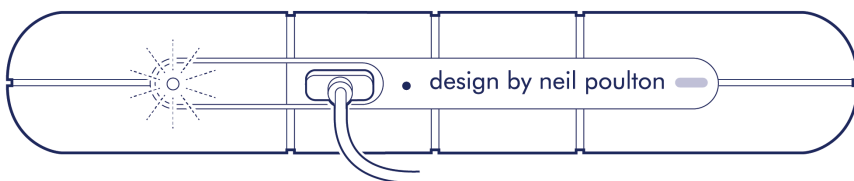

If the low power LED light is blinking, connect the power cable to Rugged RAID Shuttle and then connect the

power supply to a live power outlet.

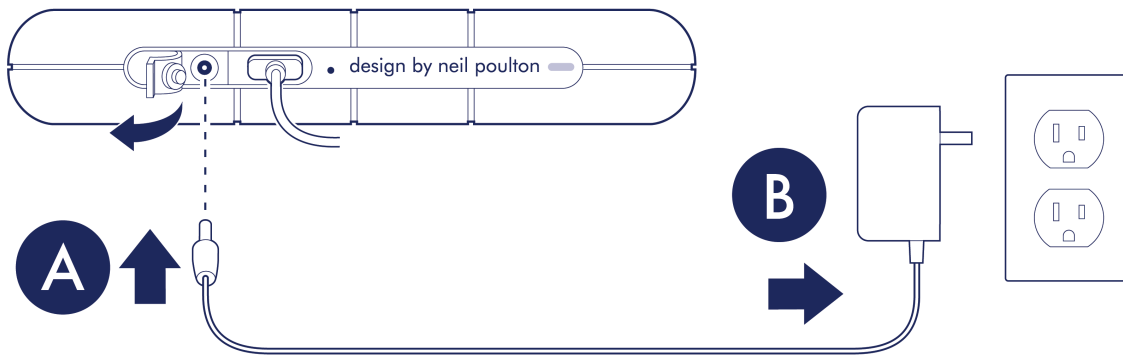

Power-saving mode

Your Rugged RAID Shuttle can conserve energy by entering power-saving mode. Managed by your computer, power-saving mode can extend the life of the hard drives by sparing them from working during extended periods of inactivity.

Operating system

You can initiate power-saving mode on your computer by performing one of the following:

- Placing the host computer in sleep mode.
- **macOS**—Go to [System Preferences > Energy Saver](#) to enable sleep mode for hard drives.
- **Windows**—Go to [Control Panel > Hardware > Power Options > Choose a power plan > Change advanced power settings](#). Click on [Hard disk](#) and [Turn off the hard disk after](#). Choose the time to spin down USB hard drives.

To exit power-saving mode, review the table below:

Entering power-saving mode	Exiting power-saving mode
The host computer placed the product into power-saving mode due to inactivity.	Access the Rugged RAID Shuttle volume on the host computer. For example, copy files to the volume.
The computer is in sleep mode.	Wake up the computer.



Note on ejecting the volume and power-saving mode—Rugged RAID Shuttle enters power-saving mode when its volume is ejected and the device remains connected to the computer. To access Rugged RAID Shuttle's volume, unplug the interface cable from the computer and then reconnect it.

Cables and Connectors

USB-C protocols

USB is a serial input/output technology for connecting peripheral devices to a computer. USB-C is the latest implementation of this standard and it provides higher bandwidth and new power management features.

USB-C supports many protocols:

Port	Transfer rates
Hi-Speed USB 2.0	up to 480Mb/s
SuperSpeed USB 3.0	up to 5Gb/s
USB 3.1 Gen 1	up to 5Gb/s
USB 3.1 Gen 2	up to 10Gb/s
Thunderbolt 3	up to 40Gb/s

The USB-C port on LaCie Rugged RAID Shuttle is USB 3.1 Gen 1. You can connect your Rugged RAID Shuttle to any USB-C port on your computer.

Cables

Use the USB-C cable to connect Rugged RAID Shuttle to a USB-C port on your computer.

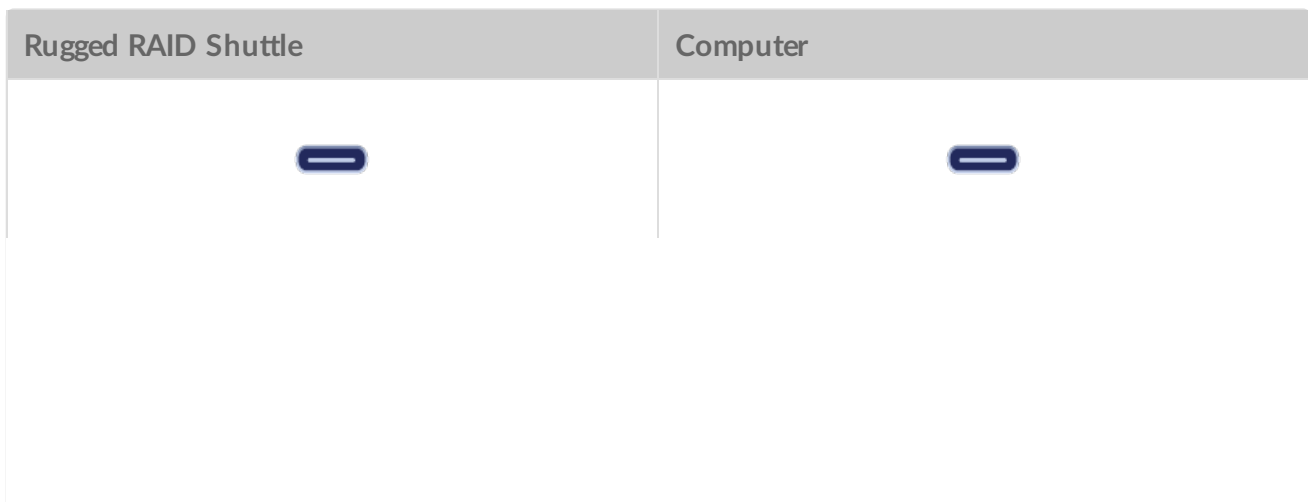

Rugged RAID Shuttle

Computer



Getting Connected

1 Connect the USB cable

Use the USB-C cable to connect LaCie Rugged RAID Shuttle to a USB-C port on your computer.

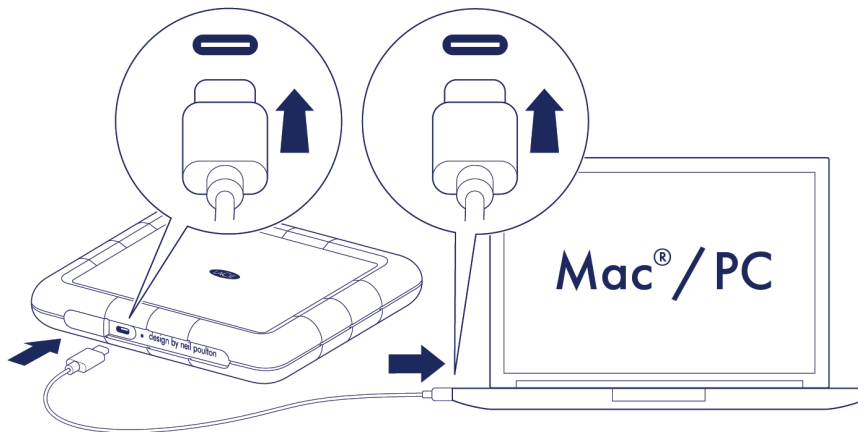

2 Check for power

LaCie Rugged RAID Shuttle is designed to operate using power from the USB connection to your computer. If the USB connection isn't delivering enough power for Rugged RAID Shuttle to operate, the low power LED blinks.

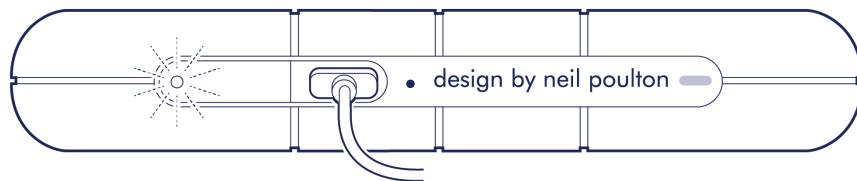

If the low power LED is blinking, connect the power cable to Rugged RAID Pro and then connect the power supply to a live power outlet.

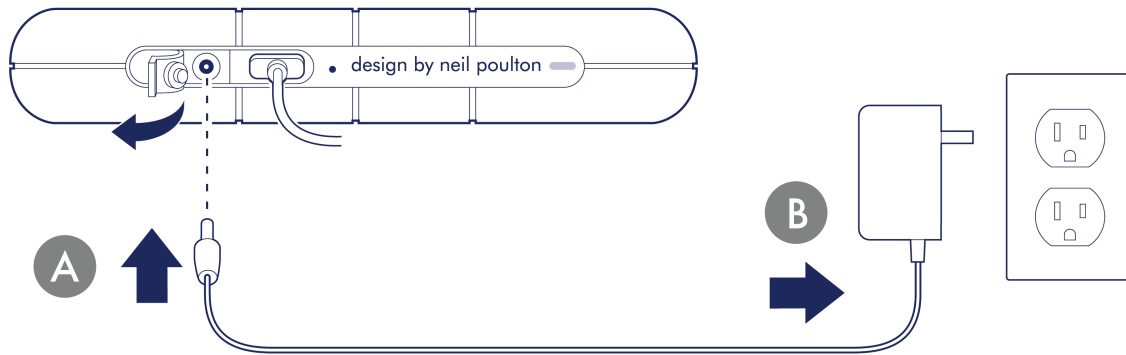

3 Set up LaCie Rugged RAID Shuttle

The setup process helps you:

Register your device

Get the most from your device with easy access to information and support.

Install Toolkit

Choose your RAID level, enable security, manage backup plans and mirror folders, and much more.



Your computer must be connected to the internet to install Toolkit.



LaCie Rugged RAID Shuttle is delivered preformatted as exFAT and configured as RAID 0 for full storage capacity. Files are not mirrored in RAID 0—if a disk fails, you may lose data. You can change the configuration to RAID 1, which protects data in case one disk fails. To learn more about RAID levels, see [Manage RAID](#).

A Start here

Using a file manager such as File Explorer or Finder, open LaCie Rugged RAID Shuttle and launch [Start Here Mac](#) or [Start Here Win](#).



Mac®



Windows®

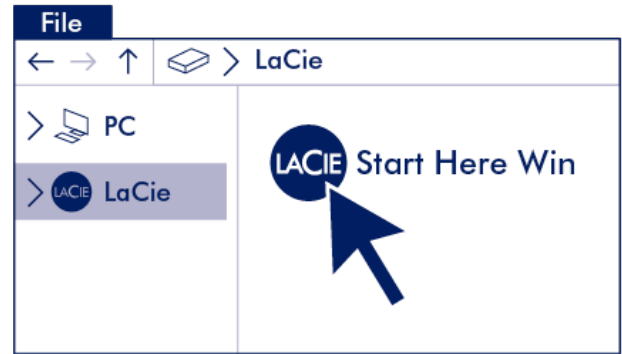

B Register your device

Enter your information and click [Register](#).

Register

I have read and agree to...

- Terms and Conditions
- Privacy Statement
- Optional Offers

C Download Toolkit

Click the [Download](#) button.



D Install Toolkit

Using a file manager such as Finder or File Explorer, go to the folder where you receive downloads.

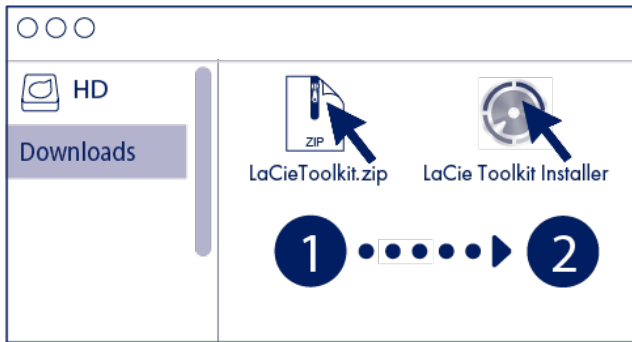

Windows

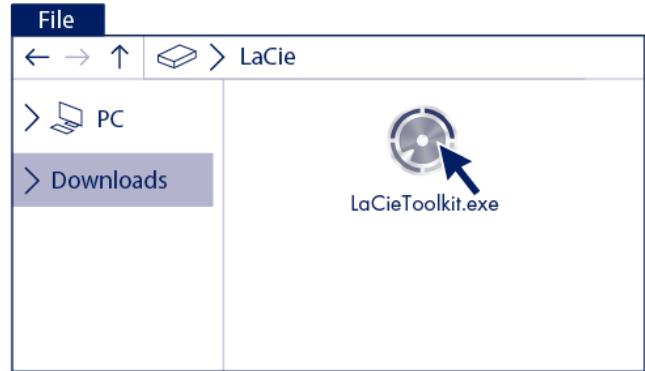

Open the [SeagateToolkit.zip](#) file. Click on the [Seagate Toolkit Installer](#) to launch the application.



Windows

Click on the [SeagateToolkit.exe](#) file to launch the application.



Your computer must be connected to the internet to install and run Toolkit.

Use Toolkit to Set Up Security, Mirror Folders, and More

Toolkit provides useful tools that let you easily manage security, set up mirror folders, and much more.

Enable security

Toolkit is required to enable security for LaCie Rugged RAID Shuttle. Be sure to install Toolkit in order to password-protect your device using Seagate Secure 256-bit encryption.

- [Click here](#) for details on enabling security.

Set up a mirror folder

Create a Mirror folder on your PC or Mac that is synced to your storage device. Whenever you add, edit, or delete files in one folder, Toolkit automatically updates the other folder with your changes.

- [Click here](#) for details on creating a mirror folder.

Start a backup plan (Windows only)

Create a plan customized for the content, storage device, and schedule of your choosing.

- [Click here](#) for details on setting up a backup plan.

Manage RAID

RAID stands for redundant array of independent disks. RAID contains the word array, and the two terms are often used interchangeably. An array is a combination of two or more physical disks that are presented to the operating system as a single device.

Disks are combined into different RAID configurations known as RAID levels. The RAID level you choose depends on which storage attributes are most important to you:

Capacity	The total amount of data you can store.
Performance	The speed at which data is copied.
Protection	The number of disks that can fail before data is lost.

Your LaCie Rugged RAID Shuttle can be configured as RAID 0 or RAID 1. Each RAID level has its own advantages:

RAID level	Capacity	Protection	Speed	Factory default
RAID 0	100%	None	Excellent	Yes
RAID 1	50%	Excellent	Good	No



Note—Rugged RAID Shuttle uses Seagate Secure encryption, which does not support a JBOD configuration.

Comprehensive RAID management

You can manage RAID levels and formatting using LaCie RAID Manager, a comprehensive tool for all of your RAID-compatible devices.

Learn more about LaCie RAID Manager

[LaCie RAID Manager for 2-Bay Devices](#)
[Download LaCie RAID Manager](#)
[Supported operating systems](#)

Safely Remove Device From Your Computer

Always eject a storage drive from your computer before physically disconnecting it. Your computer must perform filing and housekeeping operations on the drive before it is removed. Therefore, if you unplug the drive without using the operating system's software, your files can become corrupt or damaged.

Windows

Use the Safely Remove tool to eject a device.

1. Click the Safely Remove Hardware icon in your Windows System Tray to view the devices you can eject.
2. If you don't see the Safely Remove Hardware icon, click the Show hidden icons arrow in the system tray to display all icons in the notification area.
3. In the list of devices, choose the device you want to eject. Windows displays a notification when it is safe to remove the device.
4. Disconnect the device from the computer.

Mac

There are several ways you can eject your device from a Mac. See below for two options.

Eject via Finder window

1. Open a Finder window.
2. On the sidebar, go to Devices and locate the drive you want to eject. Click the eject symbol to the right of the drive name.
3. Once the device disappears from the sidebar or, the Finder window closes, you can disconnect the interface cable from your Mac.

Eject via Desktop

1. Select the desktop icon for your device and drag it to the Trash.
2. When the device icon is no longer visible on your desktop, you can physically disconnect the device from your Mac.

Optional Formatting and Partitioning

Your device is preformatted exFAT (Extended File Allocation Table) for compatibility with both Mac and Windows computers.

Choosing a file system format

When choosing a file system format, consider whether **compatibility** or **performance** is more important in your everyday use of the drive.

- **Compatibility**—You need a cross-platform format because you connect your drive to both PCs and Macs.
- **Performance**—You connect your drive with only one type of computer, so you can optimize file copy performance by formatting the drive in the native file system for your computer operating system.

Compatibility with both Windows and Macs

exFAT is a lightweight file system compatible with all versions of Windows and modern versions of macOS. If you use your drive with both PCs and Macs, format your drive in exFAT. While exFAT offers cross-platform access to both computers, keep in mind the following:

- exFAT is not compatible or recommended for built-in backup utilities such as File History (Windows) and Time Machine (macOS). If you want to use one of these backup utilities, you should format the drive in the native file system for the computer running the utility.
- exFAT is not a journaled file system, which means it can be more susceptible to data corruption when errors occur or the drive is not disconnected properly from the computer.

Optimized performance for Windows

NTFS (New Technology File System) is a proprietary journaling file system for Windows. macOS can read NTFS volumes, but it can't natively write to them. This means your Mac can copy files from an NTFS-formatted drive, but it can't add files to or remove files from the drive. If you need more versatility than this one-way transfer with Macs, consider exFAT.

Optimized performance for macOS

Apple offers two proprietary file systems.

Mac OS Extended (also known as Hierarchical File System Plus or HFS+) is an Apple file system used since 1998 for mechanical and hybrid internal drives. macOS Sierra (version 10.12) and earlier use HFS+ by

default.

APFS (Apple File System) is an Apple file system optimized for solid state drives (SSDs) and flash-based storage systems, though it also works with hard disk drives (HDDs). It was first introduced with the release of macOS High Sierra (version 10.13). APFS can only be read by Macs running High Sierra or later.

When choosing between Apple file systems, consider the following:

- Windows cannot natively read or write to APFS or HFS+ volumes. If you need cross-platform compatibility, you should format the drive in exFAT.
- If you intend to use your drive with Time Machine:
 - The default format for macOS Big Sur (version 11) and later is APFS.
 - The default format for macOS Catalina (version 10.15) and earlier is HFS+.
- If you intend to use your drive to move files between Macs running older OS versions, consider formatting your drive in HFS+ rather than APFS.
- macOS file systems and Android: Formatting your drive for macOS may not be supported with connections to Android mobile devices.

Learn more

For additional considerations when choosing a file system format, see [File System Format Comparisons](#).

Formatting instructions

For instructions on formatting your drive, see [How to format your drive](#).

Stand Accessory

You can use the included stand accessory to place your Rugged RAID Shuttle in an upright position.

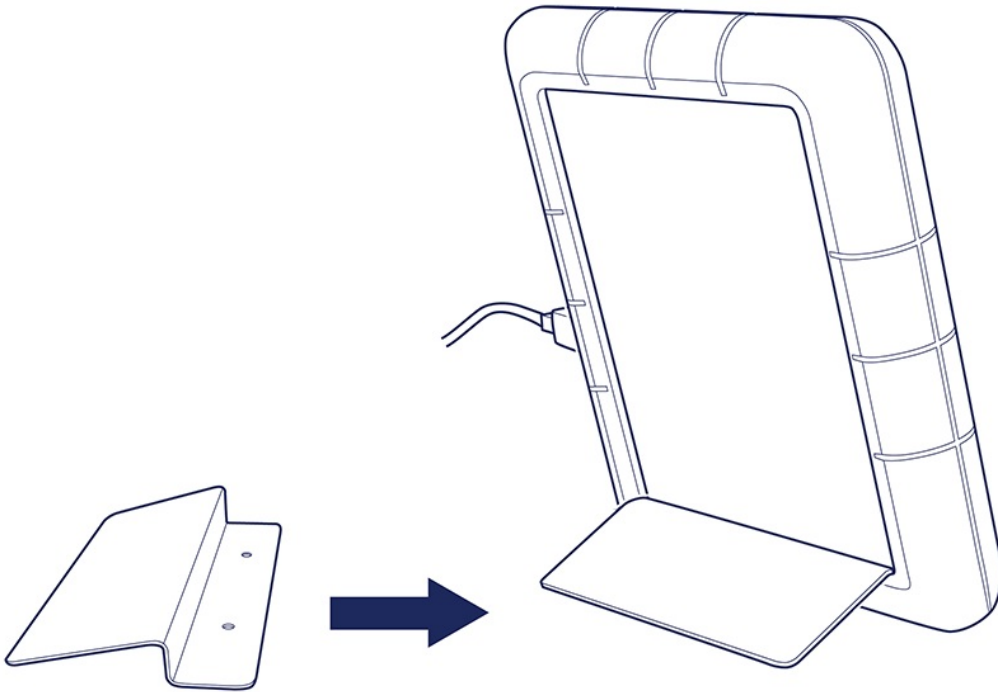

Installing the stand

Lift the protective bumper on any of the three edges that do not house the ports and LEDs. (Important—Do not attempt to install the stand on the edge with the ports and LEDs.)

Slide the narrow edge of the stand under the bumper.

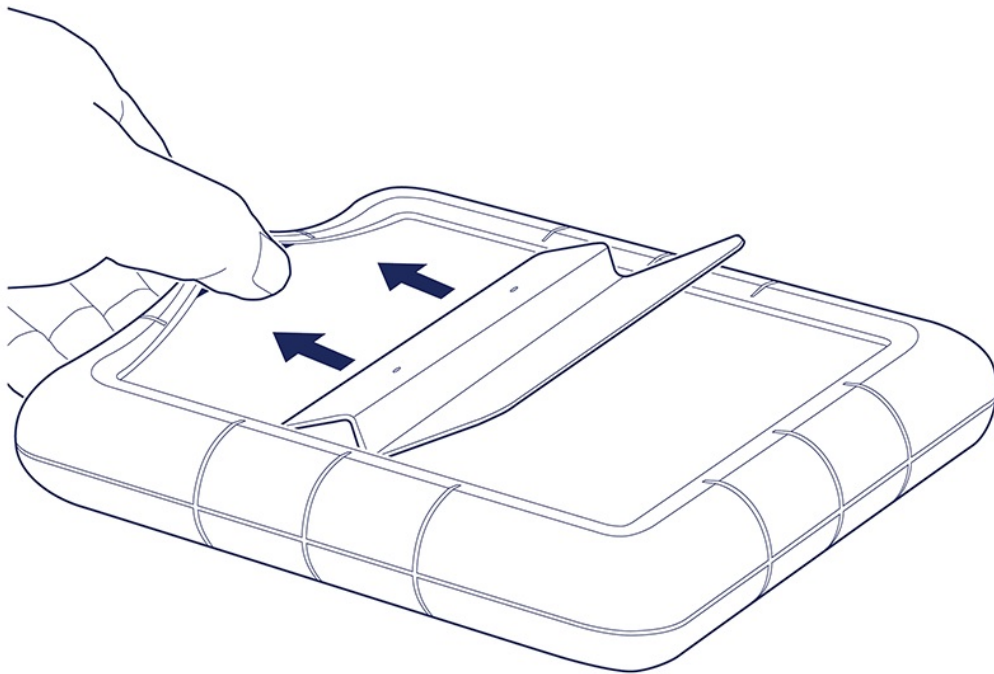

Gently push the stand at an angle to insert it between the bumper and the drive enclosure.

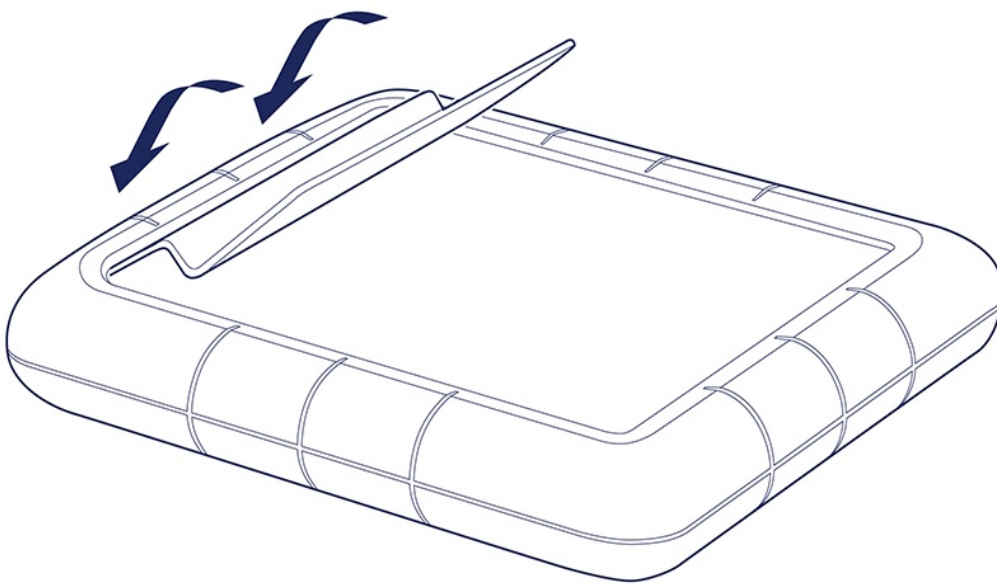

Release when the stand is locked in place.

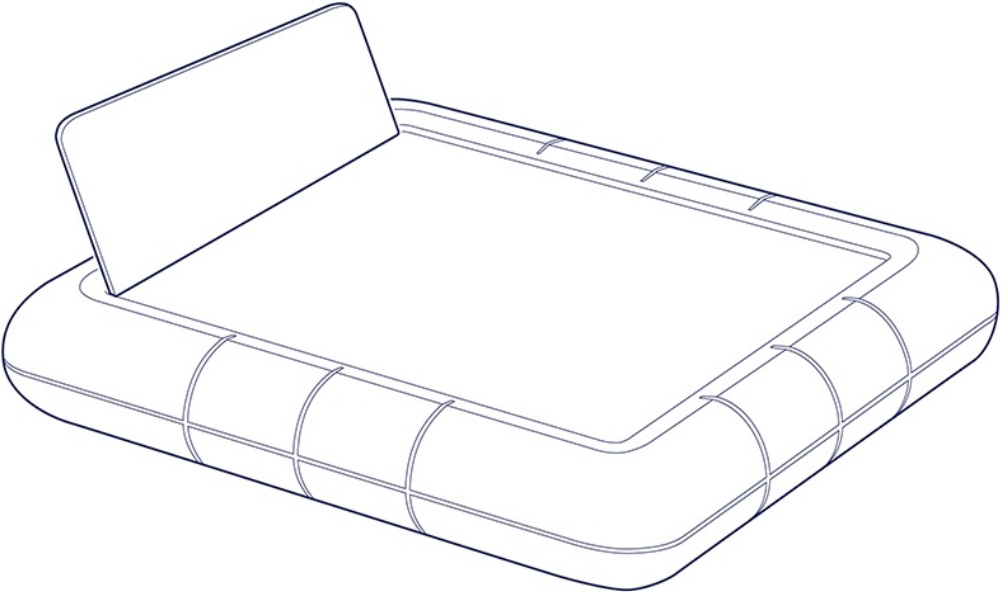

Frequently Asked Questions

For help setting up and using your LaCie hard drive, review the frequently asked questions below. For additional support resources, go to [LaCie customer support](#).

Hard drive icon

[Why does the hard drive icon not appear on my desktop \(Mac\)?](#)

[Is your Finder configured to hide hard drives on the desktop?](#)

Go to Finder and then check [Preferences > General tab > Show these items on the desktop](#). Confirm that [Hard Disks](#) is selected.

[Is your hard drive mounting in the operating system?](#)

Open Disk Utility at [Go > Utilities > Disk Utility](#). If the hard drive is listed in the left-hand column, check your Finder preferences to see why it is not displayed on the desktop (review the question above).

[Does your computer's configuration meet the minimum system requirements for use with this hard drive?](#)

For detailed information on supported operating systems, please see the following [knowledge base article](#).

[Did you follow the correct installation steps for your operating system?](#)

Review the installation steps in [Getting Connected](#).

[Why does the hard drive icon not appear in Computer \(Windows\)?](#)

[Is the hard drive listed in Device Manager?](#)

All drives appear in at least one place in Device Manager.

Type `Device Manager` in Search to launch it. Look in the Disk Drives section and, if necessary, click the Plus (+) icon to view the full list of devices. If you're uncertain that your drive is listed, safely unplug it and then reconnect it. The entry that changes is your LaCie hard drive.

Is your hard drive listed next to an unusual icon?

Windows Device Manager usually provides information about failures with peripherals. While the Device Manager can assist with troubleshooting most problems, it may not display the exact cause or provide a precise solution.

An unusual icon next to the hard drive can reveal a problem. For example, instead of the normal icon based on the type of device, it has an exclamation point, question mark or an X. Right click this icon and then choose [Properties](#). The General tab provides a potential reason why the device is not working as expected.

File transfers

Why are my file transfers slow?

Are both ends of the USB cable firmly attached?

Review troubleshooting tips for cable connections below:

- Check both ends of the USB cable and make sure that they are fully seated in their respective ports.
- Try disconnecting the cable, waiting 10 seconds, and then reconnecting it.
- Try a different USB cable.

Is the hard drive connected to a Hi-Speed USB 2.0 port on your computer or hub?

If your hard drive is connected to a Hi-Speed 2.0 port or hub, the inferior performance is normal. LaCie Rugged RAID Shuttle performance will improve when it is connected to a USB 3.1 port or a SuperSpeed USB 3.0 port. Otherwise, the device operates at slower USB transfer rates.

Are there other USB devices connected to the same port or hub?

Disconnect other USB devices and see if the hard drive's performance improves.

File transfer error messages

Why did I get an error message telling me that the drive has been disconnected when coming out of sleep mode?

Ignore this message since the drive remounts on the desktop despite the pop-up. LaCie drives conserve power by spinning down when you set your computer to sleep mode. When the computer awakes from sleep mode, the drive may not have enough time to spin up, causing the pop-up to appear.

Why did I get an “Error -50” message while copying to a FAT32 volume?

When copying files or folders from a computer to a FAT32 volume, certain characters in the names cannot be copied. These characters include, but are not limited to: ? < > / \ :

Check your files and folders to ensure that these characters are not in the names.

If this is a recurring problem or you cannot find files with incompatible characters, consider reformatting the drive to NTFS (Windows users) or HFS+ (Mac users). See [Optional Formatting and Partitioning](#).

Using a USB hub for USB devices

Can I use my hard drive with a USB hub?

Yes, the hard drive can be connected to a USB hub. If you use a hub and encounter detection problems, slower than normal transfer rates, random disconnection from your computer or other unusual issues, try connecting the hard drive directly to the computer’s USB port.

Some USB hubs are less than efficient with power management, which can be problematic for connected devices. In such a case, you may have to use LaCie Rugged RAID Shuttle’s included power supply or consider substituting a powered USB hub with its own power cable.

Please note that USB 2.0 hubs limit your hard drive’s transfer rates to USB 2.0 speeds.

Provided USB cables

Can I use my hard drive with a longer cable?

Yes, provided it is certified according to USB standards. However, LaCie recommends using the cable shipped with your hard drive for the best results. If you use a longer cable and experience problems with detection, transfer rates or disconnection, use the original cable included with your hard drive.

USB 2.0 ports

Will my hard drive’s USB 3.1 Gen 1 port work with my computer’s USB 2.0 port?

Yes, the cable end that plugs into the computer (USB Type A) is compatible with both USB 3.0 and USB 2.0. Make certain to use the included cable with the correct USB Type A connector. However, the transfer rates are much slower with USB 2.0.

RAID levels

Why doesn't LaCie RAID Manager support JBOD ("just a bunch of disks") as a RAID level for Rugged RAID Shuttle?

Rugged RAID Shuttle uses Seagate Secure encryption, which does not support a JBOD configuration.

Regulatory Compliance

Product Name	LaCie Rugged RAID Shuttle
--------------	---------------------------

Regulatory Model Number	LRDOSVO
-------------------------	---------

China RoHS



China RoHS 2 refers to the Ministry of Industry and Information Technology Order No. 32, effective July 1, 2016, titled Management Methods for the Restriction of the Use of Hazardous Substances in Electrical and Electronic Products. To comply with China RoHS 2, we determined this product's Environmental Protection Use Period (EPUP) to be 20 years in accordance with the Marking for the Restricted Use of Hazardous Substances in Electronic and Electrical Products, SJT 11364-2014.

中国 RoHS 2 是指 2016 年 7 月 1 日起施行的工业和信息化部令第 32 号“电力电子产品限制使用有害物质管理办法”。为了符合中国 RoHS 2 的要求，我们根据“电子电气产品有害物质限制使用标识”(SJT 11364-2014) 确定本产品的环保使用期 (EPUP) 为 20 年。

部件名称 Part Name	有害物质 Hazardous Substances					
	铅 (Pb)	汞 (Hg)	镉 (Cd)	六价铬 (Cr ⁺⁶)	多溴联苯 (PBB)	多溴二苯醚 (PBDE)
硬盘驱动器 HDD	X	O	O	O	O	O
外接硬盘印刷电路板 Bridge PCBA	X	O	O	O	O	O
电源 (如果提供) Power Supply (if provided)	X	O	O	O	O	O
接口电缆 (如果提供) Interface cable (if provided)	X	O	O	O	O	O
其他外壳组件 Other enclosure components	O	O	O	O	O	O

本表格依据 SJ/T 11364 的规定编制。

This table is prepared in accordance with the provisions of SJ/T 11364-2014

O: 表示该有害物质在该部件所有均质材料中的含量均在 GB/T 26572 规定的限量要求以下。

O: Indicates that the hazardous substance contained in all of the homogeneous materials for this part is below the limit requirement of GB/T26572.

X: 表示该有害物质至少在该部件的某一均质材料中的含量超出 GB/T 26572 规定的限量要求。

X: Indicates that the hazardous substance contained in at least one of the homogeneous materials used for this part is above the limit requirement of GB/T26572.

Taiwan RoHS

Taiwan RoHS refers to the Taiwan Bureau of Standards, Metrology and Inspection's (BSMI's) requirements in standard CNS 15663, Guidance to reduction of the restricted chemical substances in electrical and electronic equipment. Beginning on January 1, 2018, Seagate products must comply with the "Marking of presence" requirements in Section 5 of CNS 15663. This product is Taiwan RoHS compliant. The following table meets the Section 5 "Marking of presence" requirements.

台灣RoHS是指台灣標準局計量檢驗局(BSMI)對標準CNS15663要求的減排電子電氣設備限用化學物質指引。從2018年1月1日起，Seagate產品必須符合CNS15663第5節「含有標示」要求。本產品符合台灣RoHS。下表符合第5節「含有標示」要求。

產品名稱：外接式硬碟，型號：LRD0SV0

Product Name: LaCie Rugged RAID Shuttle, Model: LRD0SV0

單元 Unit	限用物質及其化學符號 Restricted Substance and its chemical symbol					
	鉛 (Pb)	汞 (Hg)	鎘 (Cd)	六價鉻 (Cr ⁺⁶)	多溴聯苯 (PBB)	多溴二苯醚 (PBDE)
硬盤驅動器 HDD	—	○	○	○	○	○
外接硬盤印刷電路板 Bridge PCBA	—	○	○	○	○	○
電源 (如果提供) Power Supply (if provided)	—	○	○	○	○	○
傳輸線材 (如果提供) Interface cable (if provided)	—	○	○	○	○	○
其他外殼組件 Other enclosure components	○	○	○	○	○	○

備考 1. “○” 係指該項限用物質之百分比含量未超出百分比含量基準值。

Note 1. “○” indicates that the percentage content of the restricted substance does not exceed the percentage of reference value of presence.

備考 2. “—” 係指該項限用物質為排除項目。

Note 2. “—” indicates that the restricted substance corresponds to the exemption.